



# KEEPSAFE™ Sentinel Shield

The PPS Keepsafe™ Sentinel Shield is an easy to mount solution that provides high-level results protecting associates and customers alike.

In an ever-changing environment, no one knows what threats may emerge. The PPS Keepsafe™ series is designed to **PROTECT** People and Profits, **PREVENT** Loss and **SECURE** your bottom line.

## General Use and Application

- Retail check-stands and lanes
- C-Stores
- Grocery
- Restaurants
- Customer service areas/desks
- Return/Service desks
- Pharmacy counters
- Drive-thru activities

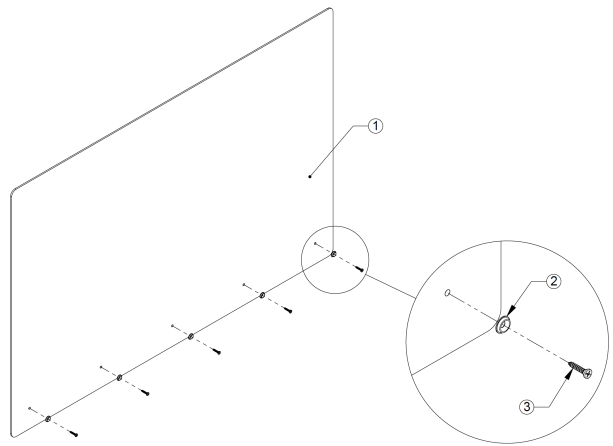

## ADDITIONAL INFORMATION

- Standard or customized sizes available (including thickness and method of attachment)
- Expedited Domestic Production and Shipping
- Discounts for Bulk Orders
- Easily installed by in-store construction teams
- Installation support available for large-scale roll-outs
- Easily sanitized with common multi-surface disinfectant
- Scratch resistant
- Rounded corners and edges designed to prevent customer or associate injury